

Forgemaster™

COMPANION Model 10000

COMPANION

Model No. 10000

Part List:

1. 10101 – Orifice
2. 10102 – Brass Valve
3. 30100 – Housing Top
4. 30101 – Housing Base
5. 10105 – Ignitor
6. 10106 – Lead Wire w/Terminal
7. 10107 – Spark Plug
8. 10108 – Hold Down Bolt w/Nut(4)
9. 10112 – Hearth Brick w/Clip
10. 10117 – Top Liner
11. 10118 – Heat Shield
12. 10119 – Re-Liner Kit (incl. 9, 10, 11)
13. 99000 – Coupling
14. 10122 – Gauge
15. 10126 – LP Regulator Kit (incl gauge with Assembled Fittings)
16. 10127 – 9' LP Hose

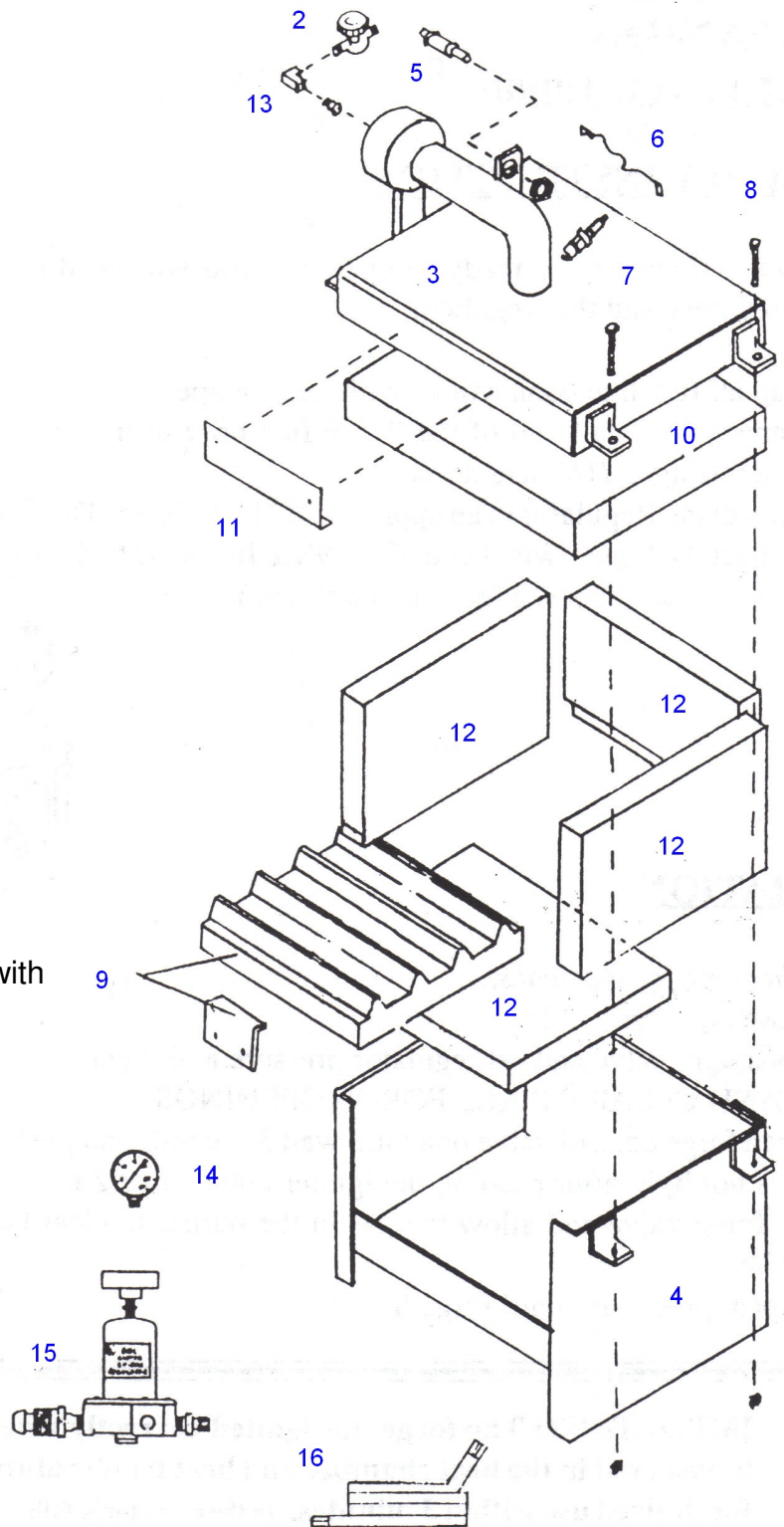

(See Reverse Side of Assembly and Operation)

COMPANION

Model 10000

www.forgemaster.com

ASSEMBLY INSTRUCTIONS:

The COMPANION model comes nearly ready to operate. You will need to install the 9' LP Fuel supply hose and the Regulator.

1. Wrap all fuel line connections with Teflon Tape.
2. Connect the small end of the 9' LP fuel hose to the brass valve at the back of the burner using a 5/8" wrench.
3. Connect the Regulator to an approved LP tank (Note: This is a left-hand thread).
4. Connect the large, swivel end of the 9' LP fuel hose to the LP regulator using a 3/4" wrench (Note: This is a left-hand thread).
5. Check for gas leaks. Refer to Owners Manual.

OPERATION:

After for Checking for Gas Leaks...

1. Close all valves.
2. Open tank valve and set regulator pressure at 10-12 psi.
3. Open the door.
4. Close butterfly choke.
5. **STAND CLEAR OF ALL FORGE OPENINGS.**
6. Open forge control valve one turn, wait 3 seconds and push igniter button. If forge does not light after pushing the igniter button 1 or 2 times, immediately **CLOSE** the forge valve and allow the gas in the burner to clear before attempting to re-ignite.
7. Repeat procedure until forge has lit.

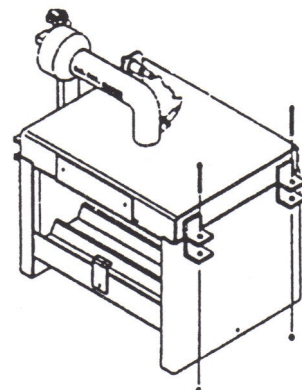

IMPORTANT: The forge has ignited correctly when blue flame is observed in the heat chamber and heat temperature is sufficient for desired use within 3 minutes. In the event of forge fails to ignite properly, see Troubleshooting section of Owners Manual

8. Open butterfly choke.
9. Increase regulator pressure as desired.
NOTE: Operating forge pressure below 5 psi. will result in below standard temperatures. Operating forge pressure above 15 psi will result in excessive fuel consumption and NOT increase forge performance.